

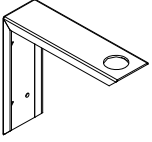





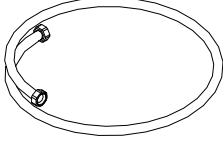

KIT VASO EXPANSIÓN SOLAR 12L/18L (TKITACU081/TKITACU082)

				
x1	x4	x1	x2	x1
1) Soporte	2) Tornillo	3) Tubo flexible (1m)	4) Junta de silicona	5) Vaso de Expansión (12L/18L)

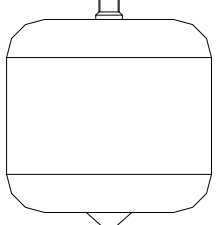
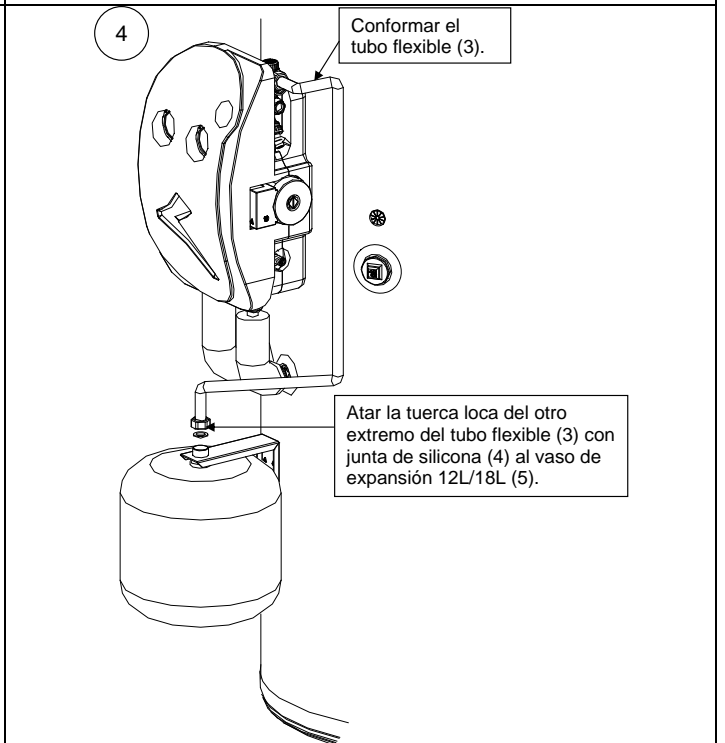
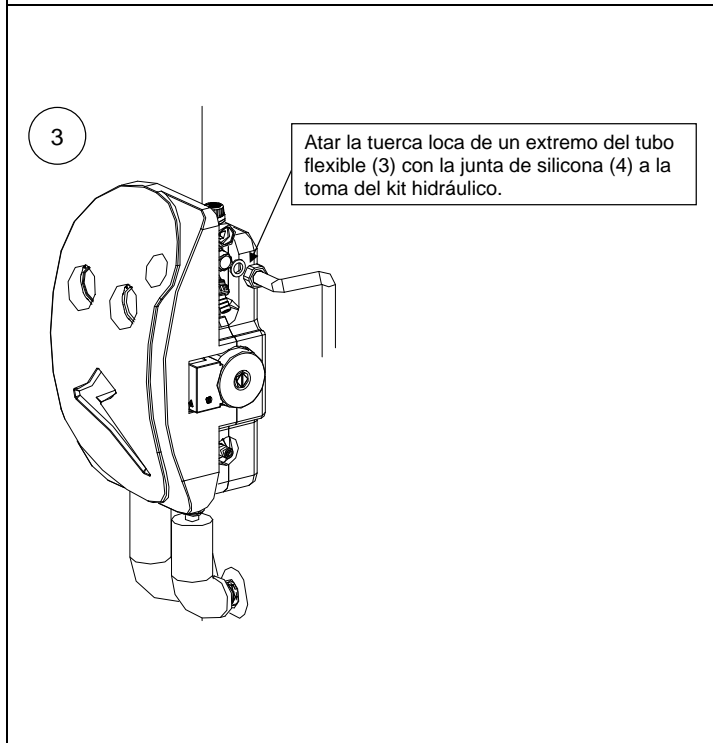
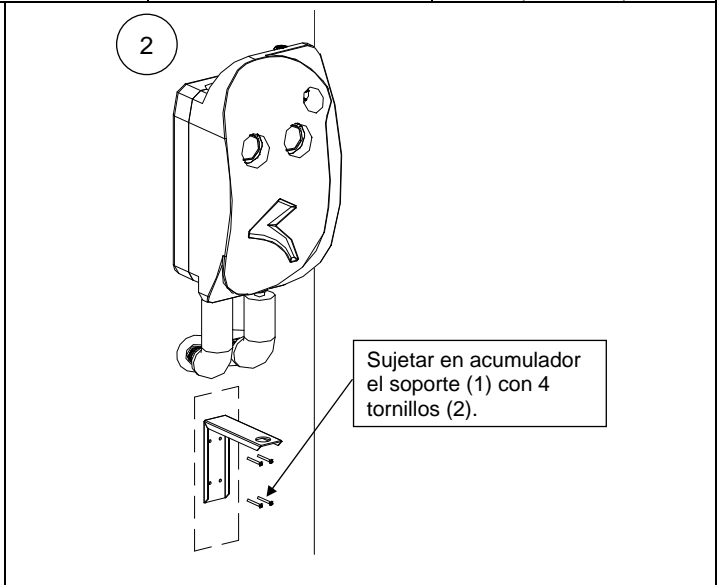
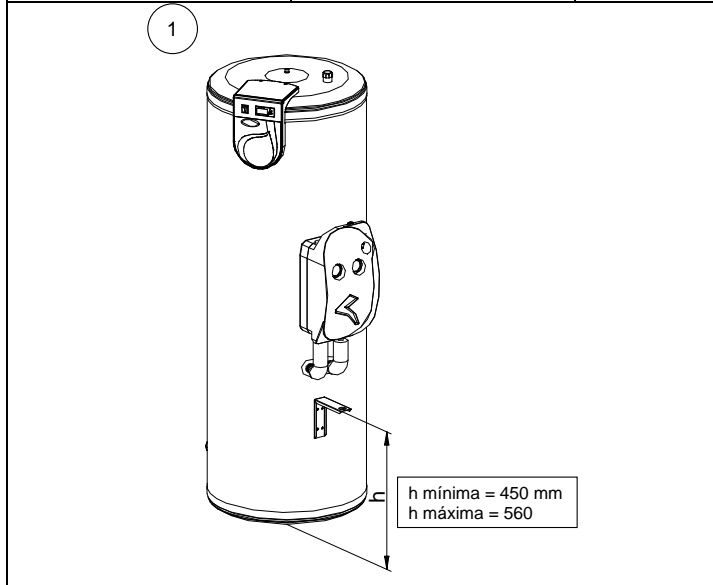
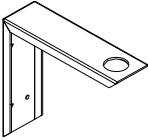

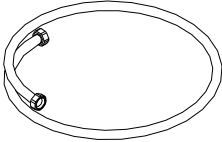

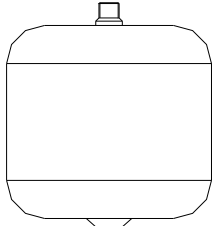

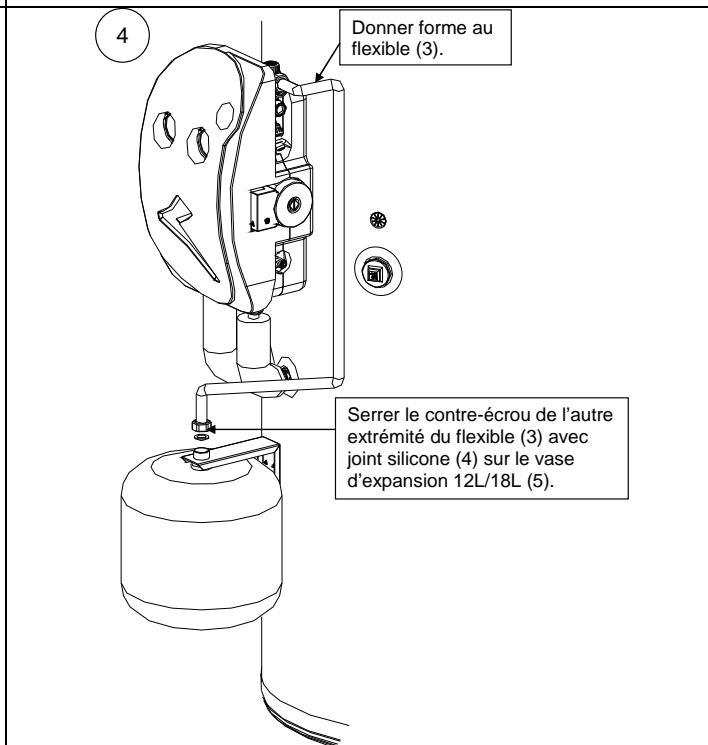
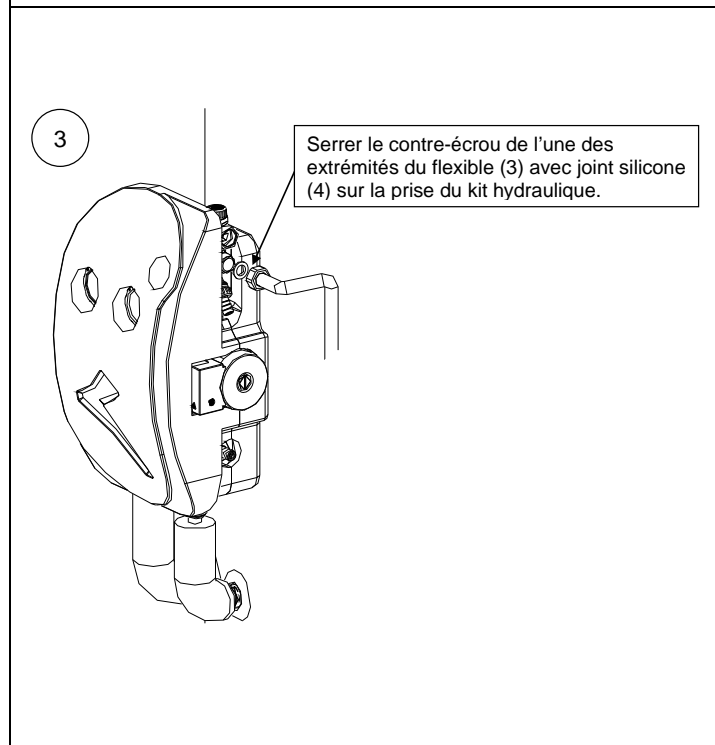
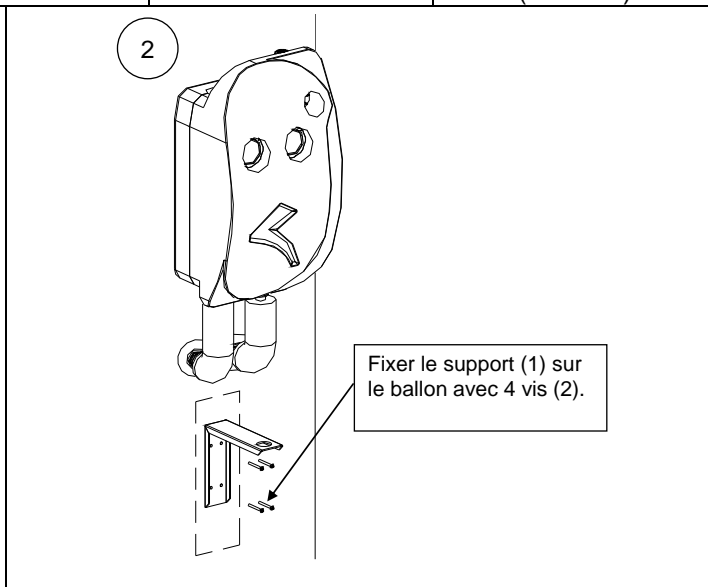
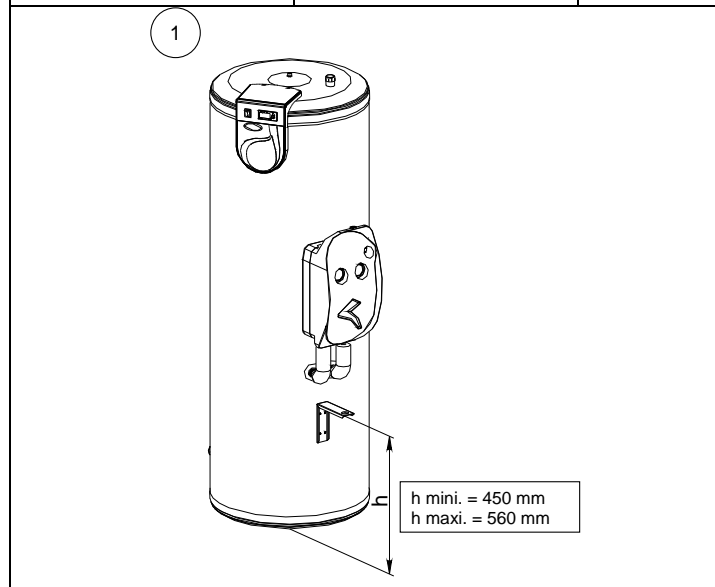
KIT VASE D'EXPANSION SOLAIRE 12L/18L (TKITACU081/TKITACU082)

				
x1	x4	x1	x2	x1
1) Support	2) Vis	3) Tuyau flexible (1m)	4) Joint silicone	5) Vase d'expansion (12L/18L)

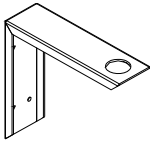

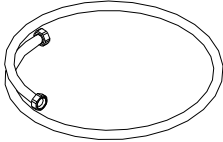
KIT VASO DE EXPANSÃO SOLAR 12L/18L (TKITACU081/TKITACU082)

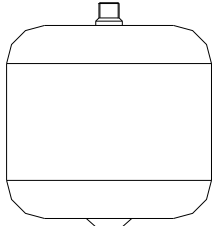
				
x1	x4	x1	x2	x1
1) Suporte	2) Parafuso	3) Tubo flexível (1m)	4) Junta de silicone	5) Vaso de Expansão (12L/18L)

